

Spring 4-14-2017

# A Community Well-Being Model: Considering AUDIT Scores and Social Class in non-Hispanic White and American Indian College Students

Violette Marie Cloud  
*University of New Mexico*

Follow this and additional works at: [https://digitalrepository.unm.edu/psy\\_etds](https://digitalrepository.unm.edu/psy_etds)

 Part of the [Psychology Commons](#)

---

## Recommended Citation

Cloud, Violette Marie. "A Community Well-Being Model: Considering AUDIT Scores and Social Class in non-Hispanic White and American Indian College Students." (2017). [https://digitalrepository.unm.edu/psy\\_etds/210](https://digitalrepository.unm.edu/psy_etds/210)

This Thesis is brought to you for free and open access by the Electronic Theses and Dissertations at UNM Digital Repository. It has been accepted for inclusion in Psychology ETDs by an authorized administrator of UNM Digital Repository. For more information, please contact [disc@unm.edu](mailto:disc@unm.edu).

Violette Marie Cloud  
*Candidate*

Psychology  
*Department*

This thesis is approved, and it is acceptable in quality and form for publication:

*Approved by the Thesis Committee:*

Dr. Kamilla Venner, Chairperson

Dr. Steven Verney

Dr. Katie Witkiewitz

**A COMMUNITY WELL-BEING MODEL:  
CONSIDERING AUDIT SCORES AND SOCIAL CLASS IN NON-HISPANIC  
WHITE AND AMERICAN INDIAN COLLEGE STUDENTS**

**BY**

**VIOLETTE M. CLOUD**

**PREVIOUS DEGREE  
BACHELORS**

**THESIS**

Submitted in Partial Fulfilment of the  
Requirements for the Degree of

**Master of Science**

The University of New Mexico  
Albuquerque, New Mexico

**May, 2017**

## DEDICATION

To my family. My parents, Hanley and Nelda Cloud. My sisters, Misty Byrd and Amber Cloud-Dance. My brother, Cody Sky Cloud. I love you guys!

## ACKNOWLEDGMENTS

Many thanks and acknowledgements are necessary. This accomplishment is due to an endless list of individuals who have supported, guided, and advised me. From high-school, through college, to my first years in graduate school, and culminating in this manuscript. I am immensely grateful to you all!

Regarding this document, I acknowledge my committee members. Dr. Kamilla Venner, my advisor and thesis chair, for her constant support, guidance, generosity and friendship. Dr. Katie Witkiewitz, without her efficient and helpful style, I would never have thought I could perform the analyses in this project much less understand them. Dr. Steven Verney, thank you for being a calm and thoughtful mentor, and for challenging me to delve deeper.

Also, deserving of recognition are my undergraduate mentors: Dr. Sue Kraus, Dr. Justin McBrayer, and Marianne Hardy. Thank you for your ongoing mentorship and encouragement. I hope I've made you proud!

Finally, I thank Natalie Bessios for keeping me on track, and for reminding me I was capable when I doubted myself. Our future is bright!

**A Community Well-Being Model: Considering AUDIT Scores and Social Class  
in non-Hispanic White and American Indian College Students**

**by**

**Violette M. Cloud**

**B.A., Philosophy and Psychology, Fort Lewis College, 2013**

**M.S., Psychology, University of New Mexico, 2017**

**ABSTRACT**

Although American Indian (AI) ethnic/racial identity and lack of social support have been linked with alcohol use problems in AI populations, little research has examined the impact of socioeconomic status, or the protective benefits of high ethnic identity with strong social connection in AI samples. This study developed and investigated a latent construct labeled community well-being (CWB) and tested it as a predictor of scores on the Alcohol Use Disorder Identification Test (AUDIT) in a sample of non-Hispanic White (NHW) and AI college students with consideration of self-reported childhood social class (birth to 18). Using structural equation modeling (SEM) this study tested the hypothesis that CWB and AUDIT scores would be negatively associated among both AI and NHW college students. We further hypothesized that among AI college students the relationship between CWB and AUDIT scores would be moderated by level of cultural identity. Secondary data analysis with NHW and AI

college students (N=254) to examine a community well-being measurement model and the relationships among CWB and AUDIT scores with consideration of ethnicity and childhood social class. Finally, this study investigated the moderating effects of cultural identity on the relationship between CWB and AUDIT scores in AI college students. Findings indicate increased CWB is associated with lower AUDIT scores for both NHW and AI college students. Lower levels of childhood social class have a strengthening effect on the negative association between CWB and AUDIT scores. Additionally, behavioral cultural identity was a near significant ( $p=.05$ ) moderator of the relationship between CWB and AUDIT scores for the AI sample.

Keywords: AUDIT, community, social class, American Indian, college students, culture

## TABLE OF CONTENTS

<b>Chapter 1: Introduction</b> .....	<b>1</b>
Socioeconomic Status and Alcohol .....	2
Indigenist-Stress Coping Model .....	3
<b>Chapter 2: Community Well-Being</b> .....	<b>4</b>
Collective Self-Esteem.....	5
Communal Mastery.....	6
Measures of Ethnic Identity .....	7
<b>Chapter 3: Methodology</b> .....	<b>11</b>
Methods.....	12
Participants and Procedure.....	13
Measures .....	14
Mental Health Continuum-Long Form (MHC-LF) .....	14
Communal Mastery (CM).....	14
Collective Self-esteem (CSE) .....	15
Alcohol Use Disorders Identification Test (AUDIT) .....	15
Social Class (SES) .....	15
Cultural Questionnaire (CQ).....	16
Microaggression Distress (MAD).....	16
Statistical Analyses .....	16
<b>Chapter 4: Results</b> .....	<b>17</b>
Descriptive Statistics.....	17
Measurement Model .....	18
Structural Models.....	18
<b>Chapter 5: Discussion</b> .....	<b>21</b>
Strengths Based Research .....	22
Alcohol Harm Paradox .....	22
Indigenist Stress-Coping Model .....	24
Limitations and Future Directions .....	24
<b>Tables</b> .....	<b>27</b>
Table 1. Correlations (Below Diagonal), Variance and Covariances (Diagonal and Above Diagonal, Respectively) of Variables for Indicator Variables .....	27



Table 2. Sample Descriptives Using t-test for Equality of Means between Non-Hispanic White (NHW) and American Indian (AI) College Students .....	28
Table 3. Results of Chi-square Test and Descriptive Statistics for Categorical Variables between Non-Hispanic White (NHW) and American Indian (AI) College Students .....	29
Table 4. Unstandardized and Standardized Factor Loadings for Community Well-Being (CWB) Measurement and Structural Models .....	30
Table 5. Unstandardized and Standardized Factor Loadings for Community Well-Being and AUDIT Scores as Moderated by Childhood Social Class .....	31
Table 6. Unstandardized and Standardized Factor Loadings for Community Well-Being and AUDIT Scores in AI College Students as Moderated by Cultural Identity (CI) .....	32
<b>Figures.....</b>	<b>33</b>
Figure 1. Baseline confirmatory factor analysis model of Community Well-Being (CWB) with five indicators; Psychological Well-Being (PWB), Emotional Well-Being (EWB), Social Well-Being (SWB), Collective Self-Esteem (CSE), and Communal Mastery (CM).....	33
Figure 2. Structural model of Community Well-Being (CWB) and Alcohol Use Disorder Identification Test (AUDIT) .....	34
Figure 3. Structural model of Community Well-Being (CWB) and Alcohol Use Disorder Identification Test (AUDIT) moderated by Social Class (SES).....	35
Figure 4. Moderation model of Cultural Identity (CI) and the structural model of Community Well-Being (CWB) and Alcohol Use Disorder Identification Test (AUDIT) predicted by Social Class (SES) in the American Indian sample only .....	36
<b>References.....</b>	<b>37</b>

## CHAPTER 1: INTRODUCTION

There is compelling evidence of health disparities by race/ethnicity in health research literature (Jones, 2006; Williams & Mohamed, 2009). However, even with the proliferation of evidence, disparities in health persist. Attempts to address racial/ethnic health disparities through research have multiplied over the last two decades, yet outcomes for racial/ethnic minorities continue to be poor in the United States (Olshansky, et al., 2012; Asada, Whipp, Kindig, Billard, & Rudolph, 2014). Three concerns about health disparity research may be contributing to the lack of improvements in health outcomes. First, such research often fails to assert race as a social construct, implying racial health disparities can be genetically deduced (Frank, 2007; Lillie-Blanton & LaVeist, 1996). Research investigating race differences highlight problems within a population compared to another, often without context. This practice highlights a ‘problem group’ rather than highlighting a social health concern and perpetuates negative stereotypes (e.g. Drunken Indian: May, 1994; Trimble, 1988). Finally, health disparity research, like other health research, is often intent on rooting out pathology and disease, rather than improving well-being and health. Due to these inadequacies in health research, racial/ethnic disparities in health endure. The current study investigates a dimension of health (hazardous alcohol use) in non-Hispanic White (NHW) and American Indian (AI) college students and aims to avoid the common pitfalls of other race/ethnicity health research, by including socioeconomic context, assessing positive levels of health and well-being, and by using culturally informed measures.

## Socioeconomic Status and Alcohol

The relationship between socioeconomic status (SES) and alcohol use problems is complex. Several non-US studies have found increased alcohol problems associated with higher SES in adult samples (Finland: Makela, 1999) while others find increased problems in lower SES in adult samples (Australia: Dietze et al., 2009). The multitude of measurement tools used to characterize both SES and alcohol problems have made such findings difficult to interpret. However, with some clarification of the measures several insights regarding the relationship between SES and alcohol use have been made. For example, when SES is determined by level of education attained or family income and alcohol problems are defined by negative consequences from use, higher SES was associated with increased alcohol use but lower SES was associated with increased experience of negative consequences in non-U.S. adult samples (Lewer, Meier, Beard, Boniface, & Kraner, 2016; Jones, Bates, McCoy, & Bellis, 2015; Beard et al., 2016). This phenomenon has been termed the alcohol harm paradox, and provides evidence to the importance of considering socioeconomic status indicators when investigating alcohol use and alcohol consequences.

The Alcohol Use Disorders Identification Test (AUDIT) has been used to investigate the alcohol harm paradox in adult samples and negative association between SES and AUDIT scores have been found, such that lower socioeconomic status is associated with higher AUDIT scores (England: Beard et al., 2016). The alcohol harm paradox and the relationship between SES and alcohol use becomes less clear when investigated by race or ethnic group. Other researchers found a pattern of high SES and heavy alcohol use held in a sample of NHWs but not for Black participants, instead, low

SES was associated with heavy alcohol use among Black participants (Lui, Chung, Ford, Grella, & Mulia, 2015). Currently, there is no available literature on SES and alcohol use in AI populations even though rates of heavy drinking (CDC, 2014; NIAAA, 2012; SAMHSA, 2013) and poverty (United States Census Bureau, 2015) are disproportionately high in AI populations. Per the 2013 SAMHSA report, the rate of substance dependence or abuse was 14.9% among AIs compared to 8.4% among Whites, for persons 12 years of age and older (NIAAA, 2014). Yet, AI populations also have higher rates of abstinence than other populations, except Asian Americans (Spicer, Novins, Mitchell, & Beals, 2003). Furthermore, per the United States Census Bureau (2015), AIs experience the highest rates of poverty at 29% compared to the general population at 15%. Given findings of other ethnic and racial groups which experience disproportionate levels of alcohol related harm depending on SES, further examination of SES indicators in alcohol use research in AI populations is warranted.

#### Indigenist-Stress Coping Model

The indigenist stress-coping model (Walters & Simoni, 2002; Walters, Simoni & Evans-Campbell, 2002) is a reconceptualization of health in AI populations. All life areas, such as, social, economic, historical, physical, and spiritual, are considered relevant to understanding health in indigenous populations. This model weighs SES information, behavioral outcomes, mental health outcomes and other health outcomes in both the present and historical cultural context. AI populations have experienced historical trauma, current oppression and discrimination, which likely contribute to poorer health outcomes (Brave Heart, Elkins, & Tafoya, 2012; Whitbeck, Hoyt, McMorris, Chen, & Stubben, 2001). Historical trauma in the form of cultural genocide (e.g. the loss of language, land,

tradition etc.) and current oppression is theorized to contribute to the health and economic disparities mentioned above. However, these populations are diverse and have an array of strengths lending them great resiliency in light of the persistent social inequalities and negative alcohol related stereotyping. Cultural strengths (e.g. family, community, and spirituality) and AI ethnic/racial identity are posited to moderate mental health outcomes (Walters & Simoni, 2002; Allen, Mohatt, Fok, Henry, & Burkett, 2014; Oetzel, Duran, Jiang, & Lucero, 2007) and nascent research supports culture, community and social connection as protective factors (Allen et al., 2014; Baldwin, Brown, Nez, Wayment, & Brelsford, 2011; LaFromboise, Hoyt, Oliver, & Whitbeck, 2006). Smith and Silva (2011) found that, for people of color, personal well-being was positively associated with ethnic identity. A finding that suggests AI ethnic identity may be associated with well-being in AI populations and is an area in need of further investigation.

## **CHAPTER 2: COMMUNITY WELL-BEING**

The proposed construct, CWB attempts to explain the underlying relationship among several sociocultural factors (i.e. communal mastery, social well-being, emotional well-being, psychological well-being, and collective self-esteem). Research into these sociocultural variables has great theoretical support (Hobfoll, Jackson, Hobfoll, Pierce, & Young, 2002; Luhtanen, & Crocker, 1992; Walters, Simoni, & Evans-Campbell, 2002), but no published studies have been completed using these five measures together. Most strengths-based research is geared toward evaluations of a person's individual strengths rather than their community strengths. Individual strengths, such as, self-esteem and self-efficacy are psychological constructs that have been extensively researched and shown to be related to beneficial health outcomes in multi-ethnic samples (Michaels, Barr, Roosa,

& Knight, 2007; Pearlin, Menaghan, Lieberman, & Mullan, 1981). However, culturally competent research and the indigenist perspective would oppose the use of culturally incongruent measures for research. Collectivistic versions of self-esteem and self-efficacy are a better fit with the indigenist perspective because they incorporate the cultural norm of collectivism rather than individualism for most AI communities. Most research literature considers esteem and efficacy on an individualistic level. However, to examine these variables with individuals from collectivistic backgrounds, we need to extrapolate to collectivistic versions of these constructs. The following describes the individualistic constructs commonly used for strengths based research and investigates collectivistic versions of each to be used in the current study.

#### Collective Self-Esteem

Crocker and Park (2004) found that working toward or applying effort to gaining self-esteem is beneficial for an individual's well-being if the pursuit is successful. Those benefits are observed in an individual's higher ratings of self-worth within important life domains, such as, work and individual relationships. For collectivistic societies, the construct of self-esteem may not be as suitable compared to individualistic societies. The evaluation of self-worth, an auxiliary of self-esteem, would be influenced by the value that is placed on independence or interdependence (Markus & Kitayama, 2003). Therefore, an evaluation of collective self-esteem might provide better information on individuals from collectivistic societies. Collective self-esteem is an evaluation of one's identity in relation to one's community (Lutanen & Crocker, 1992). Because positive self-esteem has been associated with better mental health outcomes for those from

individualistic societies, greater collective self-esteem may predict mental health outcomes in those from collectivistic societies.

### Communal Mastery

Self-efficacy is a measure of an individual's confidence level regarding his or her ability to accomplish goals. The utility of self-efficacy for improved stress responding is supported by the literature (Pearlin, Schieman, Fazio, & Meersman, 2005; Bandura, 1998). For example, greater general self-efficacy is associated with less alcohol use and better academic outcomes in college students (Baldwin, Oei, & Young, 1993). According to Hobfoll and colleagues (2000) increasing self-efficacy or the individual's sense that they are capable, is most successful when culture is considered. Having culturally consistent ways for accomplishing goals, rather than accomplishing individualistic goals that may go against cultural values, is likely beneficial to culturally diverse individuals.

Self-mastery, also a measurement of individual confidence in goal accomplishment, is interchangeable with self-efficacy (Hobfoll et al., 2002). Using an individualistic construct might miss important information compared to using a collectivistic construct, such as communal mastery, for AI populations. Communal mastery is defined as the individual's perception they are capable of handling challenges and overcoming obstacles, because their social community works with them in support of their goals. Communal mastery would theoretically be a better measure of confidence for goal achievement for those from collectivistic societies. In a study comparing personal mastery with communal mastery in a sample of 103 AI women, researchers found those participants with high communal mastery had better outcomes (measured by depressive mood and anger) than those with low communal mastery. Furthermore, high communal

mastery was more beneficial than high self-mastery for this AI population. AI women scoring high in communal mastery responded to high stress situations with less depressive mood and anger than those scoring low in communal mastery (Hobfoll et al., 2002). More research is needed to understand the role of communal mastery in AI men, as well as further investigation into the differences between self-mastery and communal mastery in collectivistic and individualistic societies.

#### Measures of Ethnic Identity

American Indians and other ethnic minority populations experience many life stressors that likely contribute to negative drinking outcomes. Perceived racial/ethnic discrimination has been shown to have strong direct effects on substance abuse onset in adolescents. One study found that perceived discrimination predicted poor outcomes in self-worth and identity establishment, in an AI sample (Whitbeck et al., 2001).

Although, high ethnic identity is associated with self-esteem, self-worth, and mental health outcomes, the associations are variable and not always positive, because there is evidence that high ethnic identity is a precursor to the experience of discrimination (Smith & Silva, 2011). Like other psychological distress, discrimination is associated with negative physical health among AI populations (Jones, 2006; Balsam, Molina, Beadnell, Simoni, & Walters, 2011). Discrimination has been shown to have detrimental effects on health outcomes in adolescents as well as adults (Whitbeck, 2001; Kessler et al., 1999). Discrimination has been shown to correlate with negative outcomes in alcohol and drug use and in mental health outcomes (Chartier & Caetano, 2009; Hatzenbuehler, McLaughlin, Keyes, & Hasin, 2010; Williams, Jackson, & Anderson, 1997; Whitbeck et al., 2001; Kessler, Mickelson, & Williams, 1999). Hurtado and



colleagues (2015) found that racial minority university students had higher racial identity salience (i.e. spent significantly more time thinking about race) and reported higher levels of bias and discrimination on college campuses which correlated to poor academic outcomes. Clearly, discrimination plays a substantial role in the health outcomes of ethnic minority populations, thus further research in this subject is warranted.

To address issues of discrimination, such as limited access to resources, racism in healthcare and research, and overall health disparities, Walters (2005) developed a microaggression scale specific to AIs. The microaggression distress scale measures the distress experienced by an AI individual as a result of specific perceived microaggressions. Racial microaggressions are everyday interactions that subtly insult an individual's ethnic identity or culture. Microaggressions can be intended or unintended but are most often covert and are therefore more difficult to discern, making them all the more difficult to combat (Sue & Sue, 2012). Experienced microaggressions have been linked with ethnic and cultural identification in AI youth, showing that high ethnic identity is associated with a greater experience of microaggressions (Jones and Galliher, 2014). Although greater experience of microaggressions has been associated with negative health outcomes for AI populations (Chae & Walters, 2009), little is known about high ethnic identity and the absence or near absence of distress in the face of experiencing microaggressions. Very low levels of microaggression distress for individuals with high ethnic identity is considered a form of cultural resilience. Cultural resilience denotes a quality of rising above or pulling through adversity (Grandbois & Sanders, 2012; Garrett, et al., 2014). Therefore, the experience of microaggressions

without distress or with diminished distress would be important to investigate, as it relates to AI cultural identity and health outcomes.

Cultural identity refers to how influential culture is to an individual's self-understanding (Whitesell et al., 2014). Cultural identity can be viewed as unidimensional, orthogonal, or multidimensional. The unidimensional version measures cultural identity on a continuum, so that the more an individual identifies with one culture, the less they identify with the other. The orthogonal version of cultural identity measures each culture separately allowing them to vary independently of the other(s). The multidimensional version of cultural identity is a dynamic measurement of the overlap and interrelationships among different domains of cultural/ethnic/racial identity such as; commitment to, behavioral involvement with and salience of group membership (Phinney & Ong, 2007). The integration of culture and other levels of identity have been shown to mediate the relation between stress and poor health in AI populations (Walters & Simoni, 2002). Multidimensional measurement of an individual's cultural identity is traditionally accomplished using either behavioral or cognitive based measures. Behavioral measures evaluate levels of engagement in culturally relevant activities and cognitive measures evaluate levels of internalization of culturally relevant values (Whitbeck, Yu, Johnson, Hoyt, & Walls, 2008).

Phinney and Ong (2007) investigated a multidimensional development model of ethnic identity; their findings suggest an individual's ethnic identity is not only being informed on cultural group values, but it is also represented by behavioral engagement with that cultural group. Ethnic behaviors include practicing culturally relevant activities such as speaking the language or eating the food. There is a strong positive relationship

between ethnic identity and racial identity salience (Phinney & Ong, 2007). Racial identity salience is the frequency and level of importance with which an individual considers their race membership. High racial identity salience has been associated with positive outcomes for individuals of a racial minority heritage (Hurtado, Alvarado, & Guillermo-Wann, 2015; Cameron, 2004), and others have found cultural identity to be unrelated to alcohol use in AI populations (Whitesell et al., 2014). When considering identity constructs, it is important to note that levels of identification will vary across individuals within a group, and measures for ethnic, racial, and cultural identity are not well understood or differentiated in the current scientific literature.

Social and cultural support have been found to be negatively associated with drinking behaviors and positively associated with overall mental health in AI populations (Walters & Simoni, 2002; Booth, Blow, Cook, Bunn, & Fortney 1992; Berkman, 1995) and discrimination has been shown to correlate with negative outcomes in alcohol and drug use and in mental health outcomes (Chartier & Caetano, 2009; Hatzenbuehler, McLaughlin, Keys, Hasin, 2010; Williams, Yu, Jackson & Anderson, 1997; Whitbeck et al., 2001; Kessler, Mickelson, Williams, 1999). However, little is known about CWB with regard to discrimination in AI populations. In fact, the vast majority of alcohol research in AI populations has focused on the various risk factors purported to contribute to the disproportionate rates of alcohol use disorders (AUD), such as stress, poverty, racism, historical trauma, and other social determinants of health (Walters, Simoni, Evans-Campbell, 2002; Whitesell et al., 2014; Jernigan, Duran, Ahn, & Winkleby, 2010; Booth, et al., 1992; Chartier & Caetano, 2009; Mail, 1996).

Keyes (2005) defines positive mental health as a measure of emotional, social and psychological well-being. Positive outcomes may be less represented in the literature because “mental health” has been constructed as being the *lack* of psychopathology rather than a positive quality in its own right (Keyes, 2005). Positive outcomes for AI populations are less represented in the literature, though the nascent research supports culture, community and social connection as protective factors (Allen, et al., 2014; Baldwin, Brown, & Wayment, 2011; LaFromboise, Hoyt, Oliver, & Whitbeck, 2006).

In the current study, the proposed latent construct labeled CWB is informed by an individual’s responses on five measures; collective self-esteem, communal mastery, psychological well-being, emotional well-being, and social well-being. The indigenist stress-coping model, as presented by Walters and Simoni (2002) attempts to assess health in AI populations within the context of sociocultural factors. The CWB model is aligned with the indigenist stress-coping model, evaluating CWB using collectivistic measures where possible and including childhood social class as a socioeconomic indicator.

### CHAPTER 3: METHODOLOGY

The current study tested a measurement model of CWB in a sample of NHW and AI college students and tested hypotheses regarding the relationship between the CWB construct and measures of alcohol problems, social class (SES), and AI cultural identity.

**Hypothesis 1:** Following the guidelines of the indigenist stress-coping model, the proposed latent variable (CWB) was constructed to explain variance in five indicators: collective self-esteem, communal mastery, psychological well-being, social well-being, and emotional well-being in AI and NHW college students. **Hypothesis 2:** A structural model with CWB, SES and AUDIT scores was hypothesized to fit these data based on

the proposed theory and established literature, such that, greater CWB would be associated with lower AUDIT scores in this sample of college students. **Hypothesis 3:** AI racial/ethnic identity is often used to explain variability in alcohol use outcomes, however, effects of socioeconomic status have been shown to unravel some of these differences. It is hypothesized that SES will moderate the association between CWB and AUDIT scores such that the negative association will be strengthened at lower levels of SES. **Hypothesis 4:** Finally, behavioral and cognitive measures of cultural identity will strengthen the negative relationship between CWB and AUDIT scores for AI college students, such that, higher levels of behavioral and cognitive cultural identity will strengthen the negative association between CWB and AUDIT scores.

#### Methods

The current study is a secondary data analysis using structural equation modeling (SEM) to examine the interrelationships among SES, ethnic identity, CWB, and hazardous alcohol use within NHW and AI college students. Following development of the initial theory, but prior to statistical analysis, the NHW sample was included to increase the sample size. Inclusion of the NHW sample led to several ethical and practical concerns. First, research using NHWs as a comparison to ethnic/racial minorities has been found to perpetuate negative stereotypes of minority groups (Helms, Jernigan, & Mascher, 2005). Rather than establishing disparities in health and providing specific areas for improvement in policy and patient care, descriptive differences between racial ethnic groups often identify problems and imply individual responsibility for those in non-white ethnic groups. In an effort to address this ethical concern, socioeconomic status (childhood social class) was included as a predictor in the analyses as suggested by

other health disparities researchers (Kawachi, Daniels, Robinson, 2005; Krieger, Chen, Waterman, Rehkopf, & Subramanian, 2003). Second, a practical concern resulted because the NHW sample did not respond to two of the measures (the Microaggression Distress Scale and the Cultural Questionnaire); therefore, these measures were investigated as moderators in the fourth hypothesis for the AI sample only. A benefit to including the NHW sample in these analyses allows for possible generalization of the indigenist stress coping model to other ethnic groups and college students.

#### Participants and Procedure

The current study is part of a larger study on protective and risk factors relating to drug and alcohol use among college students ( $N = 255$ , 40% AI; 58% Female).

Participants were recruited for the study through flyers and the University of New Mexico psychology research website. After giving informed consent, participants completed a 30-minute online screening to determine their eligibility for the larger study. Inclusion criteria for the study were: age (18-25), ethnicity (NHW or AI), and drinking severity via the AUDIT. AUDIT scores range from 0 to 40, a score of zero indicates no alcohol use and a score of 1 to 6 for women and 1 to 7 for men, indicates moderate non-hazardous alcohol use. The standard cutoff for hazardous drinking in men is a score of 8 or higher and for women a score of 7 or higher (de Menesses-Gaya, Zuardi, Loureiro, & Crippa, 2009). In this sample, 20.4% ( $n = 52$ ) were abstainers, 48.6% ( $n = 116$ ) scored in the moderate non-hazardous use range, and 31% ( $n = 87$ ) scored in the hazardous alcohol use range. Participants who met inclusion criteria completed a battery of questionnaires on various risk and protective factors for alcohol abuse and dependence. Participants were compensated one class credit per hour of research participation.

## Measures

**Mental Health Continuum-Long Form (MHC-LF).** Emotional, psychological, and social well-being were assessed using the MHC-LF (Keyes, 2005). The MHC-LF consists of 41 items divided into three subscales: positive emotional well-being (EWB), psychological well-being (PWB), social well-being (SWB). EWB scores range from 6 to 40, PWB scores range from 18 to 126, and SWB scores range from 15 to 105. Positive well-being items were presented in a 5 point Likert-type scale, responses being for the past 30 days the individual felt positive affect (e.g. “cheerful” or “full of life”) *all the time=1 to none of the time=5*. Psychological well-being was assessed using 18 items on a 7 point Likert-type scale from strongly agree to strongly disagree. An example question was, “I am good at managing the responsibilities of daily life.” Social well-being was assessed by 15 items on a 7 point Likert-type scale from *strongly agree=1 to strongly disagree=7* with questions like “I believe that people are kind.” The internal reliability for each of the MHC-LF subscales in the current sample were EWB:  $\alpha=.87$ , PWB:  $\alpha=.80$ , and SWB:  $\alpha=.80$ . (See Appendix for The Mental Health Continuum–Long form).

**Communal Mastery (CM).** The 10-item Communal Mastery Scale (Hobfoll et al., 2002) assesses the degree to which an individual feels their-social network contributes to their ability to overcome challenges. Individuals endorse collectivistic statements (e.g. “Working together with friends and family I can solve many of the problems I have”) that are rated on a 4-point Likert type scale from *strongly agree to strongly disagree*. The scale has been shown to have adequate reliability ( $\alpha=.72$ ) with a sample of AI women ages 16 to 29 (Hobfoll et al., 2002). Cronbach’s alpha of the scale in the current sample was  $\alpha=.86$ .

**Collective Self-esteem (CSE).** The 16-item Collective Self-Esteem Scale (Luhtanen & Crocker, 1992) assesses an individual's level of social identity based on their group membership. Collective self-esteem was evaluated using responses on a 7-point Likert-type scale from *strongly disagree* to *strongly agree*. Example questions are: "I am a worthy member of the social groups I belong to," and "The social groups I belong to are an important reflection of who I am." Cronbach's alpha ( $\alpha=.86$ ) suggests high reliability of this scale in this sample.

**Alcohol Use Disorders Identification Test (AUDIT).** The 10-item AUDIT (Saunders, Aasland, Babor, De la Fuente, & Grant, 1993) is used to identify levels of hazardous drinking. Scores range from 0 to 40 and the traditional cutoff for high risk drinking is 8. Various cutoffs have been proposed for the AUDIT (de Menesses-Gaya, Zuardi, Loureiro, & Crippa, 2009). Based on previous research, hazardous drinking status was operationalized as scores of 8 or higher for men and 7 or higher for women. Internal consistency reliability of the AUDIT was  $\alpha=.85$  in the current sample.

**Social Class (SES).** Many measurement issues have been raised in the assessment of socioeconomic status (Braveman, et al., 2005). Indicators, such as educational attainment, household income, vehicles owned, home ownership, and neighborhood quality have been used to measure SES. The current study assessed SES via a single item, 5 point Likert-type question, which asked: "What was your family's social class during your childhood (birth to 18)?" The response options were "Lower," "Lower-Middle," "Middle," "Upper-Middle," and "Upper." Childhood social class has been used as a socioeconomic status indicator in several other studies investigating psychological and health outcomes for adults (Bosma, Mheen, & Mackenbach, 1999; Lundberg, 1997).



**Cultural Questionnaire (CQ).** The Cultural Questionnaire (Mail, 1996) is a behavioral measure of enculturation or cultural identity. For this study, the 11-item self-report measure was adapted to include nine items about participation in and knowledge of cultural traditions. For example, one question is “Do you practice your tribe’s traditional ceremonies?” Another question asks, “What language do you speak in your home?” Possible answers are: “*Indian all the time,*” “*Indian most of the time,*” “*English most of the time,*” or “*English all of the time.*” Responses are summed; possible scores are 0-18 with higher scores meaning greater participation in cultural traditions. The two questions from the original questionnaire that were dropped from the present analyses were specific to a single tribe not represented in this sample. Internal consistency reliability of the adapted 9-item Cultural Questionnaire was  $\alpha = .82$  in the current sample of AI college students.

**Microaggression Distress (MAD).** Stress from discrimination was evaluated using the Microaggression Distress scale (Walters, 2005), a 33-item measure of participants’ experience of microaggressions. Item responses were on a five point Likert type scale ranging from “*Not at all*” bothered by the experience to “*Extremely*” bothered. A sample question is; “In your lifetime, how much were you distressed or bothered by unfair treatment by your bosses or supervisors because you are Native?” The scale has been shown to have good internal validity,  $\alpha=.97$  (Walters, 2005). In the current AI sample, the scale demonstrated good internal validity  $\alpha=.96$ .

#### Statistical Analyses

Using confirmatory factor analysis (CFA), the current study tested whether psychological well-being (PWB), social well-being (SWB), emotional well-being

(EWB), collective self-esteem (CSE), and communal mastery (CM) indicate a single latent factor named here, community well-being (CWB). Data screening for all five indicators was completed; outliers, normality, collinearity, and internal consistency reliability were assessed. All five measures demonstrated internal consistency reliability at  $\alpha = .80$  or greater, and most were normally distributed such that their kurtosis and skewness were non-significant. Communal Mastery was significantly skewed. However, because maximum likelihood estimation is robust to non-normality in data, no transformations were performed on these data. Bivariate correlations and covariances for indicator variables are shown in Table 1. Figure 1 of the hypothesized model shows that the latent factor was scaled using unit loading identification. Analyses were conducted in Mplus Version 7.4 (Muthen & Muthen, 1998-2015), where maximum likelihood estimation is the default. Adequate fit of the model was determined by a non-significant  $\chi^2$  such that  $p > .05$ , Root Mean Square Error of Approximation less than 0.05 (RMSEA; Browne & Cudeck, 1993), and a Comparative Fit Index greater than 0.95 (CFI; Bentler, 1990).

## **CHAPTER 4: RESULTS**

### Descriptive Statistics

The average age of this sample (N=255) was 19.7 (SD= 1.8). A significant t-test,  $t(255) = 2.77$ ,  $p < .05$  suggests the AI sample is significantly older than the NHWs in this sample of college students (Table 2). NHWs had a greater proportion of participants reporting Upper SES, conversely AIs had a larger proportion of participants reporting Lower SES (Table 3). A Chi-square test of independence resulted in a significant association between ethnicity/race and SES,  $\chi^2(2, N=255) = 27.74$ ,  $p < .001$ . Although a

greater proportion of NHWs reported hazardous drinking than AIs, a Chi-square test of independence resulted in a non-significant difference between ethnic/racial groups and AUDIT scores, as shown in Table 3.

#### Measurement Model

Confirmatory factor analysis (CFA) was used to assess the factor structure of five observed variables (EWB, PWB, SWB, CSE, CM) to test hypothesis 1 (Figure 1). The measurement model fit the data. The  $\chi^2$  test was non-significant ( $\chi^2 (5) = 10.691, p = 0.058$ ) and the Comparative Fit Index (CFI) was 0.983. However, the Root Mean Square of Approximation (RMSEA) was 0.067 with a 90% confidence interval of [0.00- 0.123], suggesting there is some error in the model. As seen in Table 4, all loadings were above .3 for all five indicators. Although imperfect, the model is reasonably consistent with these data.

#### Structural Models

Prior to testing hypothesis 2, the structural component was included in the model (Figure 2). Including AUDIT scores in the model improved fit over the measurement model alone. The  $\chi^2$  test was non-significant and the other fit indices suggested good model fit ( $\chi^2 (9) = 14.416, p = 0.1083$ ; CFI= 0.984; and RMSEA=0.047; 90% CI= [0.00, 0.093]). There was a strong negative relationship between the CWB construct and the AUDIT (B (SE)=-3.095 (0.773),  $p < .01$ ;  $\beta = -0.278$ ). Additionally, the  $R^2$  for AUDIT scores in this model was 0.077, suggesting the CWB model accounted for 7.7% of the variance in AUDIT scores. An additional SEM analysis was performed to investigate the observed variables (age, sex, and SES) as predictors of CWB and AUDIT scores. This model did not fit these data based on a significant  $\chi^2$  test,  $\chi^2 (21) = 36.229, p = 0.0206$ ,

CFI= 0.96 and RMSEA=0.053; 90% CI= [0.021, 0.082]. The model estimates revealed a significant positive relationship between SES and CWB ( $B(SE)=0.089(0.043)$ ,  $\beta=0.145$ ,  $p<.05$ ). No significant relationship was found between SES and AUDIT scores. Both age and sex were significantly associated with AUDIT scores, (Age:  $B(SE)=0.584(0.179)$ ,  $\beta=0.192$ ,  $p<.05$ ; Sex:  $B(SE)=-1.876(0.664)$ ,  $\beta=-0.66$ ,  $p<.05$ ). Despite lack of significant relationship found between SES and AUDIT score, SES was retained as a predictor in the remaining analyses as specified in the a priori hypotheses.

For hypothesis 2, SES was tested as a predictor of CWB and AUDIT scores. This model (Figure 2) provided good fit to these data. The  $\chi^2$  test was nonsignificant,  $\chi^2(13) = 17.823$ ,  $p = 0.1643$ ; CFI= 0.986; and RMSEA=0.038; 90% CI= [0.00, 0.078]. Although the association between SES and AUDIT scores remained non-significant, the associations between SES and CWB were significant. SES and CWB were positively associated ( $B(SE)=0.096(0.042)$ ,  $\beta=0.155$ ,  $p<.05$ ). AUDIT scores and CWB had a strong negative association ( $B(SE)=-3.211(0.787)$ ,  $\beta=-0.288$ ,  $p<.01$ ). The  $R^2 = 0.082$  for AUDIT scores in this model. These results suggest the variability in AUDIT scores accounted for by the model is 8.2% and is improved from the baseline model which accounted for 7.7% of the variance in AUDIT scores. The model estimates for both the measurement and structural models are provided in Table 4.

Hypothesis 3 (figure 3) was tested by a moderation analysis of the effect of social class level on the relationship between CWB and AUDIT scores. There was a significant negative association for AUDIT scores and CWB ( $B(SE)=-3.204(0.876)$ ,  $\beta=-0.285$ ,  $p<.001$ ), and a significant positive association between AUDIT scores and the interaction term ( $B(SE)=3.001(1.102)$ ,  $\beta=0.222$ ,  $p<.05$ ).  $R^2=0.131$  for AUDIT scores suggesting this

moderation model accounted for 13% of variance in AUDIT scores. Unstandardized and standardized factor loadings are shown in Table 5.

The significant interaction was probed by testing the effects of CWB at three levels of SES via a simple slopes analysis. For “low” childhood social class, CWB had a significant negative association with AUDIT ( $B(SE)=-6.698 (1.74)$ ,  $\beta=-0.474$ ,  $p<.001$ ). At the “low” childhood social class level, ethnicity and AUDIT scores had a significant negative association ( $B(SE)=-3.529 (1.479)$ ,  $\beta=-0.025$ ,  $p<.05$ ) For “middle” childhood social class, there was a negative association between CWB and AUDIT scores  $B(SE)=-2.465 (0.981)$ ,  $\beta=-0.245$ ,  $p<.05$  and the association between ethnicity and AUDIT scores was non-significant. However, neither CWB nor ethnicity was significantly associated with AUDIT scores in the “upper” childhood social class group.

Finally, the fourth hypothesis was tested via two separate moderation analyses, using AIs only ( $n=103$ ), investigating the effects of cultural identity based on the scores from the Cultural Questionnaire (CQ) and the Microaggressions Distress Scale (MAD) on the relationship between CWB and AUDIT scores (Figure 4). The moderation analysis of the CQ revealed a significant negative association between CWB and AUDIT scores ( $B(SE)= -4.55 (1.44)$ ,  $\beta=-0.369$ ,  $p<.05$ ) and near significant negative association between the CWB and CQ interaction term and AUDIT scores,  $B(SE)= -0.76 (0.38)$ ,  $\beta=-0.243$ ,  $p=.05$ . For this model,  $R^2=0.209$ , suggesting this moderation model accounted for 21% of the variance in AUDIT scores among AI college students. The moderation analysis of the MAD revealed a significant negative association between CWB and AUDIT scores  $B(SE)=-3.978 (1.436)$ ,  $\beta=-0.356$ ,  $p<.05$ , but no association between the interaction term and AUDIT scores.  $R^2= 0.148$  for this model, suggesting that it accounted for 15% of

variance in AUDIT scores. All standardized and unstandardized factor loadings for moderation analyses are shown in Table 6.

Although neither the CQ nor the MAD resulted in a significant interaction, the CQ approached significance ( $p=.05$ ), justifying further probing. The CWB by CQ interaction was investigated via a simple slopes analysis which tested the CWB effects at three levels of cultural identity as determined by the CQ. The low CQ group was determined as one SD below the mean score and lower, ( $n=20$ ), the moderate CQ group are those within one SD of the mean score ( $n=63$ ) and high CQ are those one SD above the mean score and higher ( $n=20$ ). For the low CQ group, the association between CWB and AUDIT score was non-significant, as was the association between SES and AUDIT score. For the moderate CQ group, there was a significant negative association between CWB and AUDIT scores ( $B(SE)=-6.184 (2.308)$ ,  $\beta=-0.429$ ,  $p<.05$ ), but no significant association between SES and AUDIT scores. Similarly, for the high CQ group, there was a significant negative association between CWB and AUDIT scores ( $B(SE)=-5.618 (2.246)$ ,  $\beta=-0.503$ ,  $p<.05$ ), and SES and AUDIT scores were not associated.

## CHAPTER 5: DISCUSSION

In this sample of college students, measures of psychological well-being, emotional well-being, social well-being, communal mastery, and collective self-esteem provide insight on the underlying latent construct CWB. CWB was found to account for a meaningful amount of variance in AUDIT scores. These findings provide support to the theories preceding the proposed CWB model: strengths-based research, the alcohol harm paradox, and the indigenist stress coping model. Each help to decipher the patterns of

association between CWB and AUDIT scores in this sample of NHW and AI college students.

### Strengths Based Research

The CWB measurement model fit these data, suggesting collective self-esteem, communal mastery, social well-being, psychological well-being and emotional well-being share a similar underlying construct. The latent variable CWB, successfully measured by the five indicator variables may be understood to assess an individual's subjective account of their social connections and support networks. There is increased interest in strengths based research for health outcomes (La Fromboise, et al., 2006, Keyes, 2005). As hypothesized, CWB is protective against hazardous alcohol use. CWB was shown to be negatively associated with AUDIT scores for both AI and NHW college students. A collectivistic approach has been encouraged in the literature for AI populations (Lutanen & Crocker, 1992; Hobfoll, et al., 2001), but, surprisingly, collectivism in the form of CWB was also shown to be mildly protective for NHW college students in this study. These findings demonstrate the potential utility of using research based in AI populations to inform research in other ethnic populations including NHWs. However, without accounting for other factors such as socioeconomic status, the simple CWB structural model only accounted for 7.7% of the variance in AUDIT scores.

### Alcohol Harm Paradox

Socioeconomic status as indicated by childhood social class was shown to moderate the relationship between CWB and AUDIT scores in this study. For participants classified into the lower SES group, the negative association between CWB and AUDIT scores was strengthened. This suggests for lower SES, CWB acts as a buffer

against hazardous alcohol use in this sample of AI and NHW college students. The negative association between CWB and AUDIT scores remained significant for the middle SES group, but was not as strong of a moderator. At high levels of childhood, CWB and AUDIT were not significantly associated, suggesting the protective influence of CWB is diminished for individuals from the upper SES group. Interestingly, ethnicity proved to be a significant predictor of AUDIT scores at the lowest level of childhood social class, but not for the mid to high social class groups.

There is an abundance of research supporting the positive association between health and socioeconomic status in general (Zhang and Zhang, 2005; Scambler, 2012; Semyonov, Lewin-Epstein & Maskileyson, 2013). However, there is a growing interest in the interactive relationship of SES and race/ethnicity for health outcomes such as depression, substance use, mortality rates, and birthweights (LaVeist, 2005; Braveman et al., 2005, Adler & Ostrove, 1999, Braveman et al., 2011). The inverse relationship between alcohol use health outcomes and SES has been shown to be inconsistent when ethnicity is considered, as demonstrated by the alcohol harm paradox (Lewer, et al., 2016; Jones et al., 2015; Beard et al., 2016). In the current study, socioeconomic status appears to be helpful in predicting AUDIT scores although not equally well for both ethnic groups. Socioeconomic disparities in health are well documented, however, AI populations experience them disproportionately. Those in poverty tend to experience additional social disadvantages, such as less access to health care, education, shelter (Kaplan, Haan, Syme, Minkler & Winkleby, 1987; Smith, J.P, 1998, Alegría, et al., 2008). For participants in the lower SES group, there was a significant negative relationship between ethnicity and AUDIT scores in the combined sample of college students. AI



participants reported lower SES on average than NHWs in this sample of college students. Although self-reported social class is not a comprehensive measure of socioeconomic status, its inclusion in the CWB structural model provided needed contextual information and helped to account for more variance in AUDIT scores.

#### Indigenist Stress-Coping Model

The indigenist stress-coping model would suggest cultural identity would moderate the relationship between CWB and AUDIT scores, such that higher levels of cultural identity would strengthen the negative association between CWB and AUDIT scores. A moderation analysis of cognitive cultural identity as indicated by the Microaggression Distress Scale was not a significant moderator of the negative association between CWB and AUDIT scores. This result may be due to the complexity of measuring an individual's distress from experienced microaggression and may not be a good measure of cognitive levels of cultural identity. In contrast, the behavioral measure of cultural identity as measured by the CQ approached significance ( $p=.05$ ) as a moderator of the negative association between CWB and AUDIT scores. After probing the interaction, mid to high levels of behavioral cultural identity demonstrated significant negative associations between CWB and AUDIT scores. These findings may suggest mid to high levels of cultural identity promote CWB and are protective against hazardous alcohol use for AI college students.

#### Limitations and Future Directions

There are several limitations to the current study. First, latent variable modeling is generally used in large samples, thus there is limited power to examine relationships in this study. Confidence in the current findings would be improved if the CWB latent

factor was replicated in other samples. Second, this sample consisted solely of college students at a southwestern university, thus limiting generalizations to other AI and NHW college populations and to other age groups. Additionally, except for the measures of communal mastery, and microaggression distress the measures used in this study have not been previously used in or normed for AI populations, though the Cronbach alphas for all measures were in the recommended range. Finally, all measures were self-report and were obtained at a single time point. Future research would benefit from using objective measures and longitudinal studies on socioeconomic status (i.e. pay stubs, neighborhood safety, home ownership) and alcohol use (i.e. BAC, real-time record of use, quantity and duration). Though there are several limitations, the current study provides new insight into the relationships among CWB, AUDIT scores, SES, and race/ethnicity in a sample of AI and NHW college students.

The current study provides evidence regarding the buffering effect of CWB in college students' AUDIT scores, particularly for those reporting low childhood social class and AI ethnic origin. CWB was more protective for the AI sample of college students' AUDIT scores than the NHW college students. In the AI sample, the behavioral measure of cultural identity suggested a moderating effect, such that mid to high levels of cultural identity based on scores from the CQ were buffered against hazardous alcohol use. Interestingly, the mid CQ group was slightly more protected than the high CQ group. For the mid group this may be a sign of cultural integration, the ability to successfully integrate culture of origin with another culture (Boski, 2008). Those hoping to implement intervention or prevention programs with college students, socioeconomic context and CWB ought to be considered and addressed when designing or proposing such programs.

Similarly, for AI college students, domains of cultural identity (behavioral, cognitive, etc.) should be considered as well. CWB is a new construct that demonstrated a potential protective effect in hazardous alcohol use outcomes among AI and NHW college students. CWB may be useful in addressing alcohol related health disparities among AIs and for improving alcohol related outcomes for NHW college students.

### TABLES

Table 1. Correlations (Below Diagonal), Variance and Covariances (Diagonal and Above Diagonal, Respectively) of Variables for Indicator Variables

	EWB	PWB	SWB	CSE	CM
EWB	.515	.310	.281	.203	.111
PWB	.613**	.495	.341	.282	.103
SWB	.466**	.577**	.693	.336	.114
CSE	.325**	.459**	.465**	.758	.081
CM	.310**	.294**	.275**	.186*	.246
Mean (SD)	4.21 (.72)	5.59 (.70)	4.92 (.83)	5.30 (.87)	3.27 (.50)
N	255	255	249	254	253

\* $p < 0.05$  and \*\* $p < 0.01$

*Note.* EWB=Emotional Well-Being; PWB=Psychological Well-Being; SWB=Social Well-Being; CSE=Collective Self-Esteem; CM=Communal Mastery

Table 2. Sample Descriptives Using t-test for Equality of Means between Non-Hispanic White (NHW) and American Indian (AI) College Students

	<u>Total</u>		<u>NHW</u>		<u>AI</u>		<i>t</i> -test
	Mean (SD)	N	Mean (SD)	n	Mean (SD)	n	
Age	19.74 (1.82)	255	19.48 (1.64)	152	20.12 (2.01)	103	2.77*
AUDIT	5.59 (5.56)	255	5.86 (5.56)	152	5.19 (5.58)	103	-0.93
EWB	4.21 (0.72)	255	4.20 (0.69)	152	4.23 (0.77)	103	0.31
PWB	5.59 (0.70)	255	5.61 (0.75)	152	5.57 (0.63)	103	-0.35
SWB	4.92 (0.83)	249	4.91 (0.88)	146	4.94 (0.76)	103	0.31
CSE	5.29 (0.87)	254	5.36 (0.79)	152	5.19 (0.98)	102	-1.52
CM	3.28 (0.50)	253	3.23 (0.67)	150	3.37 (0.44)	103	2.29*

\* $p < .05$  and \*\* $p < .001$

*Note.* EWB=Emotional Well-Being; PWB=Psychological Well-Being; SWB=Social Well-Being; CSE=Collective Self-Esteem; CM=Communal Mastery. AUDIT mean score for full sample does not account for standard gender cutoffs.

Table 3. Results of Chi-square Test and Descriptive Statistics for Categorical Variables between Non-Hispanic White (NHW) and American Indian (AI) College Students

		Total	NHW	AI	$\chi^2$ (df)	$\phi$
Sex	Male	105 (41%)	76 (50%)	29 (28%)	12.10 (1) *	.218*
	Female	150 (59%)	76 (50%)	74 (72%)		
SES	Lower	24 (16%)	24 (16%)	44 (43%)	27.74 (2) **	.330*
	Middle	81 (54%)	81 (54%)	48 (47%)		
	Upper	46 (30%)	46 (30%)	11 (11%)		
AUDITCO	Abstainer	52 (20%)	27 (18%)	25 (24%)	1.81 (2)	.084
	Moderate	116 (46%)	73 (48%)	43 (42%)		
	Hazardous	87 (34%)	52 (34%)	35 (34%)		

\* $p < .05$  and \*\* $p < .001$

Note. Numbers in parentheses indicate column percentages. SES= based on Childhood social class (birth to 18). AUDITCO is determined using recommended cutoffs by gender (Female: Abstainer 0, Moderate 1-6, Hazardous 7+; Male: Abstainer 0, Moderate 1-7, Hazardous 8+).

Table 4. Unstandardized and Standardized Factor Loadings for Community Well-Being (CWB) Measurement and Structural Models

	Measurement Model			Structural Model		
	B	(SE)	$\beta$	B	(SE)	$\beta$
EWB	1.00	(0.00)	0.70	1.00	(0.00)	0.70
PWB	1.18	(0.11)**	0.84	1.19	(0.11)**	0.85
SWB	1.14	(0.12)**	0.69	1.14	(0.12)**	0.69
CSE	0.95	(0.13)**	0.55	0.94	(0.13)**	0.55
CM	0.37	(0.07)**	0.38	0.37	(0.07)**	0.38
AUDIT on CWB				-0.272	(0.10)*	-.189
CWB on SES				0.257	(0.11)*	0.16
AUDIT on SES				0.031	(0.07)	0.03

\*\* $p < 0.01$  and \* $p < 0.05$

*Note.* EWB=Emotional Well-Being; PWB=Psychological Well-Being; SWB=Social Well-Being; CSE=Collective Self-Esteem; CM=Communal Mastery. SES=Childhood (birth to 18) social class.

Table 5. Unstandardized and Standardized Factor Loadings for Community Well-Being and AUDIT Scores as Moderated by Childhood Social Class

	SES Moderation Analysis		
	B	(SE)	$\beta$
EWB	1.00	(0.00)	0.70
PWB	1.21	(0.13)**	0.86
SWB	1.14	(0.12)**	0.69
CSE	0.94	(0.14)**	0.54
CM	0.36	(0.08)**	0.36
AUDIT on CWB x SES	3.05	(1.11)*	0.22
AUDIT on CWB	-3.17	(0.87)**	-0.29
AUDIT on SES	-0.10	(0.46)	-0.02
CWB on Ethnicity	-0.003	(0.07)	-0.003
AUDIT on Ethnicity	-0.77	(0.70)	-0.07
R <sup>2</sup> for AUDIT	0.13	(0.05)*	

\*\* $p < 0.01$  and \* $p < 0.05$

*Note.* EWB=Emotional Well-Being; PWB=Psychological Well-Being; SWB=Social Well-Being; CSE=Collective Self-Esteem; CM=Communal Mastery. SES=Childhood (birth to 18) social class.



Table 6. Unstandardized and Standardized Factor Loadings for Community Well-Being and AUDIT Scores in AI College Students as Moderated by Cultural Identity (CI)

	Microaggression Distress Scale			Cultural Questionnaire		
	B	(SE)	$\beta$	B	(SE)	$\beta$
EWB	1.00	(0.00)	0.64	1.00	(0.00)	0.61
PWB	1.05	(0.18)**	0.82	1.13	(0.20)**	0.82
SWB	0.99	(0.22)**	0.65	1.09	(0.24)**	0.66
CSE	1.15	(0.31)**	0.58	1.24	(0.34)**	0.59
CM	0.42	(0.11)**	0.47	0.44	(0.12)**	0.47
AUDIT on CWB x CI	0.06	(0.06)	0.15	-0.76	(0.38)*	-0.24
AUDIT on CWB	-3.98	(1.44)*	-0.36	-4.55	(1.44)*	-0.37
AUDIT on CI	-0.03	(0.03)	-0.16	-0.13	(0.26)	-0.11
AUDIT on SES	0.27	(0.58)	0.04	0.61	(0.56)	0.07
CWB on SES	0.13	(0.07)	0.20	0.14	(0.07)*	0.20
R <sup>2</sup> for AUDIT	0.15	(0.08)		0.21	(0.10)*	

\*\* $p < 0.01$  and \* $p < 0.05$

*Note.* EWB=Emotional Well-Being; PWB=Psychological Well-Being; SWB=Social Well-Being; CSE=Collective Self-Esteem; CM=Communal Mastery. SES=Childhood (birth to 18) social class.

## FIGURES

Figure 1. Baseline confirmatory factor analysis model of Community Well-Being (CWB) with five indicators; Psychological Well-Being (PWB), Emotional Well-Being (EWB), Social Well-Being (SWB), Collective Self-Esteem (CSE), and Communal Mastery (CM).

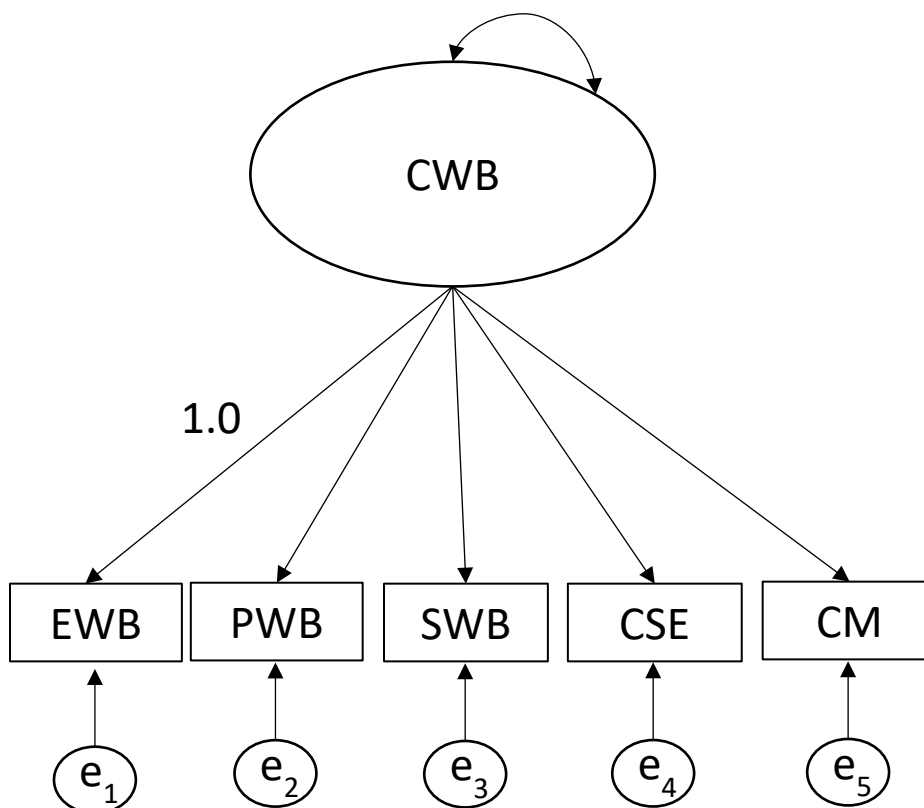

Figure 2. Structural model of Community Well-Being (CWB) and Alcohol Use Disorder Identification Test (AUDIT)

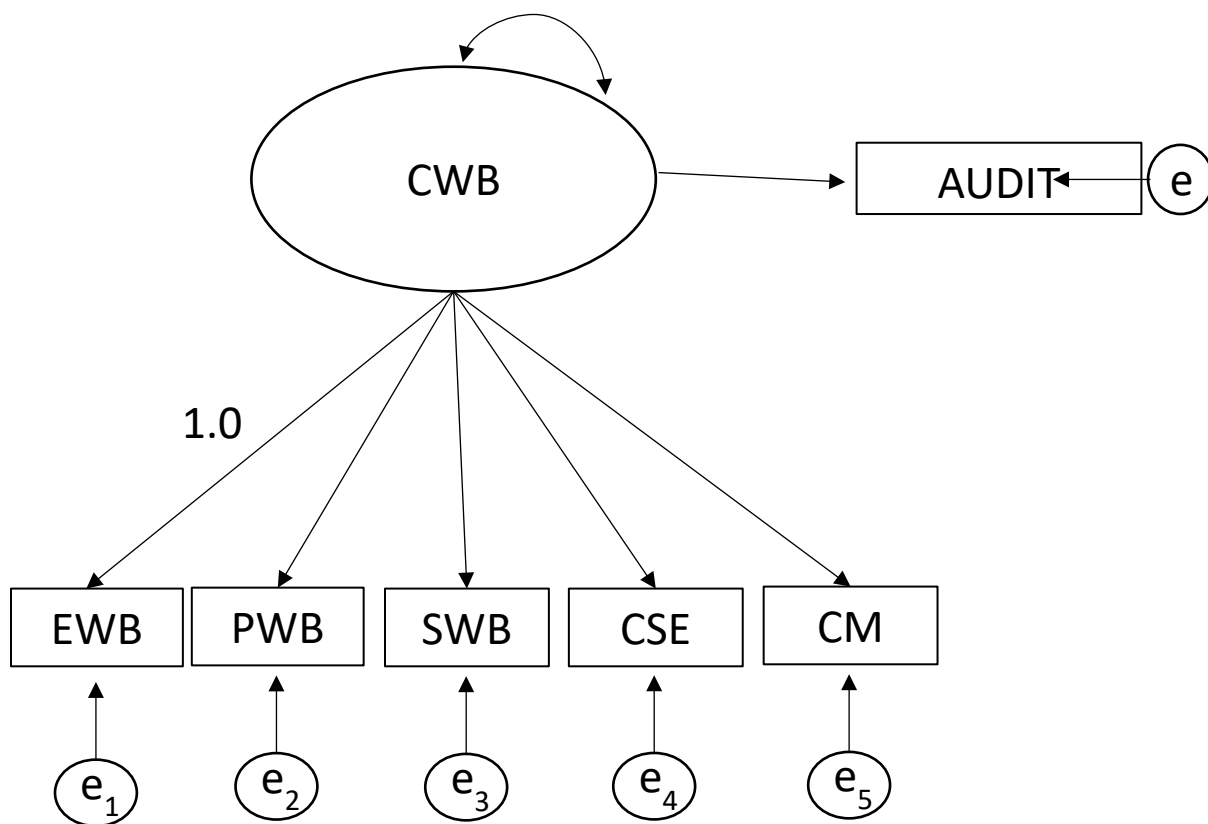

Figure 3. Structural model of Community Well-Being (CWB) and Alcohol Use Disorder Identification Test (AUDIT) moderated by Social Class (SES).

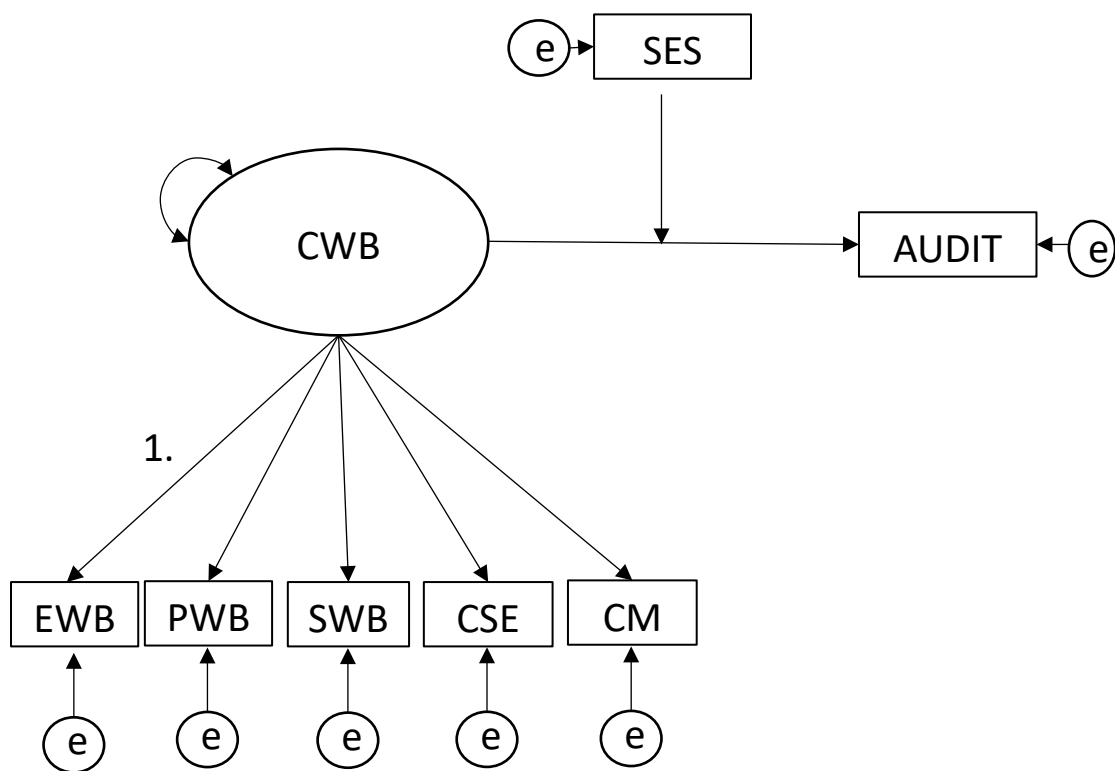
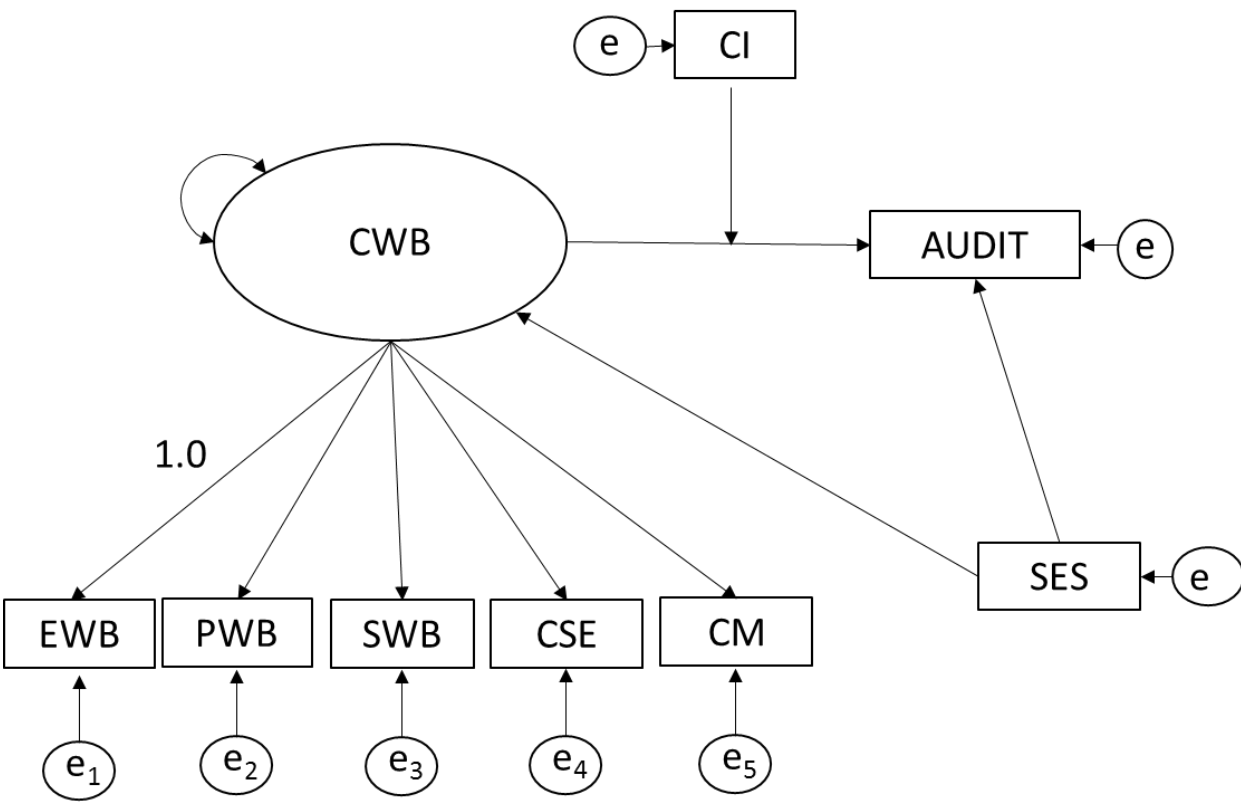

Figure 4. Moderation model of Cultural Identity (CI) and the structural model of Community Well-Being (CWB) and Alcohol Use Disorder Identification Test (AUDIT) predicted by Social Class (SES) in the American Indian sample only



Note: Two moderation analyses were performed investigation of CI in the AI sample. The first using scores from the Cultural Questionnaire (CQ) and the second using scores from the Microaggression Distress Scale (MAD).

## REFERENCES

- Adler, N. E., & Ostrove, J. M. (1999). Socioeconomic status and health: what we know and what we don't. *Annals of the New York academy of Sciences*, 896(1), 3-15.
- Alegría, M., Chatterji, P., Wells, K., Cao, Z., Chen, C. N., Takeuchi, D., ... & Meng, X. L. (2015). Disparity in depression treatment among racial and ethnic minority populations in the United States. *Psychiatric services*.
- Allen, J., Mohatt, G. V., Fok, C. C. T., Henry, D., & Burkett, R. (2014). A protective factors model for alcohol abuse and suicide prevention among Alaska Native youth. *American journal of community psychology*, 54(1-2), 125-139.
- Asada, Y., Whipp, A., Kindig, D., Billard, B., & Rudolph, B. (2014). Inequalities in multiple health outcomes by education, sex, and race in 93 US counties: Why we should measure them all. *International journal for equity in health*, 13(1), 47.
- Baldwin, J. A., Brown, B. G., Wayment, H. A., Nez, R. A., & Brelsford, K. M. (2011). Culture and context: Buffering the relationship between stressful life events and risky behaviors in American Indian youth. *Substance use & misuse*, 46(11), 1380-1394.
- Baldwin, A. R., Oei, T. P., & Young, R. (1993). To drink or not to drink: The differential role of alcohol expectancies and drinking refusal self-efficacy in quantity and frequency of alcohol consumption. *Cognitive Therapy and Research*, 17(6), 511-530.
- Balsam, K. F., Molina, Y., Beadnell, B., Simoni, J., & Walters, K. (2011). Measuring multiple minority stress: the LGBT People of Color Microaggressions Scale. *Cultural Diversity and Ethnic Minority Psychology*, 17(2), 163.

- Bandura, A. (1998). Personal and collective efficacy in human adaptation and change. *Advances in psychological science*, 1, 51-71.
- Beard, E., Brown, J., West, R., Angus, C., Brennan, A., Holmes, J., & Michie, S. (2016). Deconstructing the Alcohol Harm Paradox: A Population Based Survey of Adults in England. *PloS one*, 11(9).
- Bentler, P. M. (1990). Comparative fit indexes in structural models. *Psychological bulletin*, 107(2), 238.
- Berkman, L. F. (1995). The role of social relations in health promotion. *Psychosomatic medicine*, 57(3), 245-254.
- Booth, B. M., Blow, F. C., Cook, C. A. L., Bunn, J. Y., & Fortney, J. C. (1992). Age and ethnicity among hospitalized alcoholics: A nationwide study. *Alcoholism: Clinical and Experimental Research*, 16(6), 1029-1034.
- Boski, P. (2008). Five meanings of integration in acculturation research. *International Journal of Intercultural Relations*, 32(2), 142-153.  
doi:10.1016/j.ijintrel.2008.01.005
- Brave Heart, M. Y. H., Elkins, J., Tafoya, G., Bird, D., & Salvador, M. (2012). Wicasa Was' aka: Restoring the traditional strength of American Indian boys and men. *American journal of public health*, 102(S2), S177-S183.
- Braveman, P. A., Cubbin, C., Egerter, S., Chideya, S., Marchi, K. S., Metzler, M., & Posner, S. (2005). Socioeconomic status in health research: one size does not fit all. *Jama*, 294(22), 2879-2888.

- Braveman, P. A., Kumanyika, S., Fielding, J., LaVeist, T., Borrell, L. N., Manderscheid, R., & Troutman, A. (2011). Health disparities and health equity: the issue is justice. *American Journal of Public Health*, 101(S1), S149-S155.
- Browne, M. W., & Cudeck, R. (1993). Alternative ways of assessing model fit. Sage focus editions, 154, 136-136.
- Centers for Disease Control and Prevention (CDC), (2014). National Center for Health Statistics: Alcohol Use. Retrieved from <http://www.cdc.gov/nchs/fastats/alcohol.htm>
- Cameron, J. E. (2004). A three-factor model of social identity. *Self and identity*, 3(3), 239-262.
- Crocker, J., & Park, L. E. (2004). The costly pursuit of self-esteem. *Psychological bulletin*, 130(3), 392.
- Chartier, K., & Caetano, R. (2009). Ethnicity and health disparities in alcohol research. *Alcohol Research & Health: The Journal of the National Institute on Alcohol Abuse and Alcoholism*, 33(1-2), 152-160.
- Dietze, P. M., Jolley, D. J., Chikritzhs, T. N., Clemens, S., Catalano, P., & Stockwell, T. (2009). Income inequality and alcohol attributable harm in Australia. *BMC Public Health*, 9(1), 1.
- Frank, R. (2007). What to make of it? The (Re) emergence of a biological conceptualization of race in health disparities research. *Social science & medicine*, 64(10), 1977-1983.
- Grandbois, D. M., & Sanders, G. F. (2012). Resilience and stereotyping the experiences of Native American elders. *Journal of Transcultural Nursing*, 23(4), 389-396.



- Garrett, M. T., Parrish, M., Williams, C., Grayshield, L., Portman, T. A. A., Rivera, E. T., & Maynard, E. (2014). Invited commentary: Fostering resilience among Native American youth through therapeutic intervention. *Journal of youth and adolescence*, 43(3), 470-490.
- Hatzenbuehler, M. L., McLaughlin, K. A., Keyes, K. M., & Hasin, D. S. (2010). The impact of institutional discrimination on psychiatric disorders in lesbian, gay, and bisexual populations: A prospective study. *American Journal of Public Health*, 100(3), 452-459.
- Helms, J. E., Jernigan, M., & Mascher, J. (2005). The meaning of race in psychology and how to change it: a methodological perspective. *American Psychologist*, 60(1), 27.
- Hobfoll, S. E., Jackson, A., Hobfoll, I., Pierce, C. A., & Young, S. (2002). The Impact of Communal-Mastery versus Self-Mastery on Emotional Outcomes during Stressful Conditions: A Prospective Study of American Indian Women. *American journal of community psychology*, 30(6), 853-871.
- Hurtado, S., Alvarado, A. R., & Guillermo-Wann, C. (2015). Thinking about race: The salience of racial identity at two-and four-year colleges and the climate for diversity. *The Journal of Higher Education*, 86(1), 127-155.
- Jernigan, V. B. B., Duran, B., Ahn, D., & Winkleby, M. (2010). Changing Patterns in Health Behaviors and Risk Factors Related to Cardiovascular Disease Among American Indians and Alaska Natives. *American Journal of Public Health*, 100(4).

- Jones, D. S. (2006). The persistence of American Indian health disparities. *American Journal of Public Health, 96*(12), 2122-2134.
- Jones, L., Bates, G., McCoy, E., & Bellis, M. (2015). Relationship between alcohol-attributable disease and socioeconomic status, and the role of alcohol consumption in this relationship: a systematic review and meta-analysis. *BMC Public Health, 15* (4).  
DOI 10.118/s12889-015-1720-7
- Jones, M. L., & Galliher, R. V. (2015). Daily racial microaggressions and ethnic identification among Native American young adults. *Cultural Diversity and Ethnic Minority Psychology, 21*(1), 1.
- Kaplan, G. A., Haan, M. N., Syme, S. L., Minkler, M., & Winkleby, M. (1987). Socioeconomic status and health. *Am J Prev Med, 3*, 125-129.
- Kawachi, I., Daniels, N., & Robinson, D. E. (2005). Health disparities by race and class: why both matter. *Health Affairs, 24*(2), 343-352.
- Kessler, R. C., Mickelson, K. D., & Williams, D. R. (1999). The prevalence, distribution, and mental health correlates of perceived discrimination in the United States. *Journal of Health and Social Behavior, 208-230*.
- Keyes, C. L. (2005). Mental illness and/or mental health? Investigating axioms of the complete state model of health. *Journal of Consulting and Clinical Psychology, 73*(3), 539.
- Krieger, N., Chen, J. T., Waterman, P. D., Rehkopf, D. H., & Subramanian, S. V. (2003). Race/ethnicity, gender, and monitoring socioeconomic gradients in health: a

- comparison of area-based socioeconomic measures—the public health disparities geocoding project. *American journal of public health*, 93(10), 1655-1671.
- LaFromboise, T. D., Hoyt, D. R., Oliver, L., & Whitbeck, L. B. (2006). Family, community, and school influences on resilience among American Indian adolescents in the upper Midwest. *Journal of Community Psychology*, 34(2), 193-209.
- LaVeist, T. A. (2005). Disentangling race and socioeconomic status: a key to understanding health inequalities. *Journal of Urban Health*, 82(3), iii26-iii34.
- Lewer, D., Meier, P., Beard, E., Boniface, S., & Kaner, E. (2016). Unravelling the alcohol harm paradox: a population-based study of social gradients across very heavy drinking thresholds. *BMC Public Health*, 16(1), 599.
- Lillie-Blanton, M., & Laveist, T. (1996). Race/ethnicity, the social environment, and health. *Social Science & Medicine*, 43(1), 83-91.
- Luhtanen, R., & Crocker, J. (1992). A collective self-esteem scale: Self-evaluation of one's social identity. *Personality and Social Psychology Bulletin*, 18(3), 302-318.
- Lui, C. K., Chung, P. J., Ford, C. L., Grella, C. E., & Mulia, N. (2015). Drinking behaviors and life course socioeconomic status during the transition from adolescence to adulthood among whites and blacks. *Journal of Studies on Alcohol and Drugs*, 76(1), 68.
- Lundberg, O. (1997). Childhood conditions, sense of coherence, social class and adult ill health: exploring their theoretical and empirical relations. *Social Science & Medicine*, 44(6), 821-831.

- Mail, P. D. (1996). Cultural orientation and positive psychological status as protective factors against problem behaviors in southwestern American Indian adolescents (Unpublished dissertation). University of Maryland, College Park, MD.
- Makela, P. (1999). Alcohol-related mortality as a function of socio-economic status. *Addiction*, 94(6), 867-886.
- Markus, H. R., & Kitayama, S. (2003, January). Models of agency: Sociocultural diversity in the construction of action. In Nebraska symposium on motivation (Vol. 49, pp. 1-58).
- May, P. A. (1994). The epidemiology of alcohol abuse among American Indians: The mythical and real properties. *American Indian Culture and Research Journal*, 18(2), 121-143.
- May, P. A. (1977). Explanations of American Indian drinking: A literature review. *The Plains Anthropologist*, 223-232.
- de Meneses-Gaya, C., Zuardi, A. W., Loureiro, S. R., & Crippa, J. A. S. (2009). Alcohol Use Disorders Identification Test (AUDIT): An updated systematic review of psychometric properties. *Psychology & Neuroscience*, 2(1), 83.
- Michaels, M., Barr, A., Roosa, M., & Knight, G. (2007). Self-Esteem. *The Journal of Early Adolescence*, 27(3), 26.
- Muthén, L. K., & Muthén, B. O. (1998-2011). Mplus User's Guide. Sixth Edition. Los Angeles, CA: Muthén & Muthén.
- NIAAA, National Institute on Alcohol Abuse and Alcoholism (2012). Alcohol Use Disorder. Retrieved from <https://niaaa.nih.gov/alcohol-health/overview-alcohol-consumption/alcohol-use-disorders>

NIAAA, National Institute on Alcohol Abuse and Alcoholism (2014). Alcohol facts and statistics. Retrieved from <http://www.niaaa.nih.gov/alcohol-health/overview-alcohol-consumption/alcohol-facts-and-statistics>

Oetzel, J., Duran, B., Jiang, Y., & Lucero, J. (2007). Social Support and Social Undermining as Correlates for Alcohol, Drug, and Mental Disorders in American Indian Women Presenting for Primary Care at an Indian Health Service Hospital. *Journal of Health Communication, 12*(2), 187-206. Doi: 10.1080/10810730601152771

Olshansky, S. J., Antonucci, T., Berkman, L., Binstock, R. H., Boersch-Supan, A., Cacioppo, J. T., ... & Jackson, J. (2012). Differences in life expectancy due to race and educational differences are widening, and many may not catch up. *Health Affairs, 31*(8), 1803-1813.

Pearlin, L. I., Menaghan, E. G., Lieberman, M. A., & Mullan, J. T. (1981). The stress process. *Journal of Health and Social Behavior, 337-356*.

Pearlin, L. I., Schieman, S., Fazio, E. M., & Meersman, S. C. (2005). Stress, health, and the life course: Some conceptual perspectives. *Journal of Health and Social Behavior, 46*(2), 205-219.

Phinney, J. S., & Ong, A. D. (2007). Conceptualization and measurement of ethnic identity: Status and future directions. *Journal of Counseling Psychology, 54*(3), 271.

SAMHSA, Substance Abuse and Mental Health Services Administration (2013). Substance Abuse Facilities Data/NSSATS. Retrieved from

<http://www.samhsa.gov/data/substance-abuse-facilities-data-nssats/reports?tab=10>.

Saunders, J. B., Aasland, O. G., Babor, T. F., De la Fuente, J. R., & Grant, M. (1993).

Development of the alcohol use disorders identification test (AUDIT): WHO collaborative project on early detection of persons with harmful alcohol consumption-II. *Addiction*, 88(6), 791-804.

Scambler, G. (2012). Health inequalities. *Sociology of Health & Illness*, 34(1), 130-146.

doi:10.1111/j.1467-9566.2011.01387.x

Semyonov, M., Lewin-Epstein, N., & Maskileyson, D. (2013). Where wealth matters

more for health: The wealth–health gradient in 16 countries. *Social Science & Medicine*, 81, 10-17.

Smith, J. P. (1998). Socioeconomic status and health. *The American Economic Review*,

88(2), 192-196.

Smith, T. B., & Silva, L. (2011). Ethnic identity and personal well-being of people of

color: a meta-analysis. *Journal of Counseling Psychology*, 58(1), 42.

Spicer, P., Novins, D. K., Mitchell, C. M., & Beals, J. (2003). Aboriginal social

organization, contemporary experience and American Indian adolescent alcohol use. *Journal of studies on alcohol*, 64(4), 450-457.

Sue, D. W., & Sue, D. (2012). *Counseling the culturally diverse: Theory and practice*.

John Wiley & Sons.

Trimble, J. E. (1988). Stereotypical images, American Indians, and prejudice. In

Eliminating racism (pp. 181-202). Springer US.

- United States Census Bureau (2015). Tribal Affairs: American Indian and Alaska Native. Retrieved from <https://www.census.gov/aian/>
- Walters, K. L., (2005). Microaggression Distress Scale (Unpublished). University of Washington, Seattle, WA.
- Walters, K. L., & Simoni, J. M. (2002). Reconceptualizing Native women's health: An "Indigenist" Stress-Coping Model. *American Journal of Public Health, 92*(4), 520-524.
- Walters, K. L., Simoni, J. M., & Evans-Campbell, T., (2002). Substance use among American Indians and Alaska Natives: incorporating culture in an "Indigenist" Stress-Coping Paradigm. *Public Health Reports (1974-), 117*, S104–S117.
- Williams, D. R., Yu, Y., Jackson, J. S., & Anderson, N. B. (1997). Racial differences in physical and mental health socio-economic status, stress and discrimination. *Journal of health psychology, 2*(3), 335-351.
- Williams, D. R., & Mohammed, S. A. (2009). Discrimination and racial disparities in health: evidence and needed research. *Journal of behavioral medicine, 32*(1), 20-47.
- Whitbeck, L. B., Hoyt, D. R., McMorris, B. J., Chen, X., & Stubben, J. D. (2001). Perceived discrimination and early substance abuse among American Indian children. *Journal of health and social behavior, 405-424*.
- Whitbeck, L. B., Yu, M., Johnson, K. D., Hoyt, D. R., & Walls, M. L. (2008). Diagnostic prevalence rates from early to mid-adolescence among indigenous adolescents: First results from a longitudinal study. *Journal of the American Academy of Child & Adolescent Psychiatry, 47*(8), 890-900.

- Whitesell, N. R., Asdigian, N. L., Kaufman, C. E., Crow, C. B., Shangreau, C., Keane, E. M., ... & Mitchell, C. M. (2014). Trajectories of substance use among young American Indian adolescents: Patterns and predictors. *Journal of Youth and Adolescence*, 43(3), 437-453.
- Zhang, J., & Zhang, J. (2005). The effect of life expectancy on fertility, saving, schooling and economic growth: theory and evidence. *The Scandinavian Journal of Economics*, 107(1), 45-66.